

Det Kgl. Danske Videnskabernes Selskab.

Mathematisk-fysiske Meddelelser **VII**, 15.

THE HOT-WIRE MANOMETER

BY

MARTIN KNUDSEN



KØBENHAVN

HOVEDKOMMISSIONÆR: ANDR. FRED. HØST & SØN, KGL. HOF-BOGHANDEL
BIANCO LUNOS BOGTRYKKERI

1927

Introduction.

For the measurement of the gas pressure in an apparatus the loss of heat from a thin metal wire heated by an electric current has often been employed. Thus it is a well-known demonstration experiment that the current required to make an incandescent lamp give out light when exhausted of gas is much less than if the lamp contains some gas. In the following I shall describe an apparatus, the hot-wire manometer, which is based on this well-known principle.

The results of my investigation proved that by employing the hot-wire manometer it was possible to achieve considerably greater accuracy in the measurement of small variations in pressure within a range of from 200 to $\frac{1}{1000}$ mm. mercury pressure than with any other manometer. Thus a series of measurements made at a hydrogen pressure of 427.0 bar (Dyn per cm^2) showed that a series of variations in pressure of 3.126 bar was determined with a mean error of 0.0043 bar, which is about $\frac{1}{1000}$ of the variation in pressure, and about $\frac{1}{100000}$ of the total pressure. For the measurements to be reliable it is necessary that the glass walls that contain the gas are kept at constant temperature.

To give a large range of measurement to the hot-wire manometer it is necessary to use a very thin metal wire,

for only in that case does the loss of heat at such great pressures vary appreciably with the pressure. It is also necessary to use a thin wire in view of the measurement of pressures as low as 1 bar, for only in that case can the length of the wire, with reasonable dimensions of the apparatus, be made so much greater than the thickness that the conduction of heat through the ends of the wire does not strongly reduce the sensitivity. This will appear when we consider the following.

Let the length of the wire be L cm., its circular cross-section area A cm² and its heat conduction coefficient κ . Let T_1 be the difference between the mean temperature of the wire and the temperature of the surroundings, and let $Q T_1$ be the development of heat in the wire per sec., while $Q_1 T_1$ is the amount of heat given out through the side surface per sec., and $Q_2 T_1$ the amount of heat conducted through both ends per sec. Letting

$$c = \frac{4 A \kappa}{L}$$

we get the following equations with good approximation

$$\frac{Q}{c} = x^2 \frac{1}{1 - \frac{1}{x} Tg x} \quad \frac{Q_1}{c} = x^2 \quad \frac{Q_2}{c} = x^2 \frac{\frac{1}{x} Tg x}{1 - \frac{1}{x} Tg x}$$

where x is an auxiliary quantity which may be eliminated, and $Tg x$ is the hyperbolic tangent to x . If $q_1 T_1$ be the average amount of heat given out from each cm² of the side surface of the wire per sec., it will be seen that

$$\frac{Q_1}{c} = x^2 = \frac{L^2 q}{2 R \kappa},$$

where $2R$ is the diameter of the wire. In order to facilitate the application of the formulas we give the following extract from the tables, having

$$Q = Q_1 + Q_2$$

$$x = 0.0000 \quad 0.0100 \quad 0.1000 \quad 0.2000 \quad 0.4000 \quad 0.8000$$

$$\frac{Q_1}{c} = 0.0000 \quad 0.0001 \quad 0.0100 \quad 0.0400 \quad 0.1600 \quad 0.6400$$

$$\frac{Q_2}{c} = 3.0000 \quad 3.0000 \quad 3.0021 \quad 3.0081 \quad 3.0321 \quad 3.1257$$

$$x = 1.0000 \quad 1.5000 \quad 2.0000 \quad 2.5000 \quad 3.0000 \quad 4.0000 \quad 5.0000$$

$$\frac{Q_1}{c} = 1.0000 \quad 2.2500 \quad 4.0000 \quad 6.2500 \quad 9.0000 \quad 16.0000 \quad 25.0000$$

$$\frac{Q_2}{c} = 3.1944 \quad 3.4236 \quad 3.7224 \quad 4.0748 \quad 4.4668 \quad 5.3333 \quad 6.2500$$

For $x > 5$ we may with sufficient accuracy put $Tgx = 1$, so that we have $\frac{Q_1}{Q_2} = x - 1$.

I have found a Wollaston wire between 3 and 4 cm. long and having a diameter of 0.0002 cm. a convenient wire. If for this wire we put $\alpha = 0.167$ and $q = 10^{-5}$, using the gram-calorie as the unit of heat, the equation $\frac{L^2 q}{2R\alpha} = x^2$ will give $x = 1.64$. From the table it will appear that, for this value of x , Q_2 is still somewhat greater than Q_1 , a little more heat being thus lost by conduction through the ends of the wire than the amount given out by radiation. These amounts of heat being wasted for measurement, the hot-wire manometer is not particularly suited for measuring very low pressures. Its range of measurement lies chiefly between 1 bar and 250000 bar, or between $\frac{1}{1000}$ and 200 mm. mercury pressure.

Making of the Manometer.

The ends of a piece of Wollaston wire of the desired length, 3 to 4 cm., are fastened by silver solder to platinum

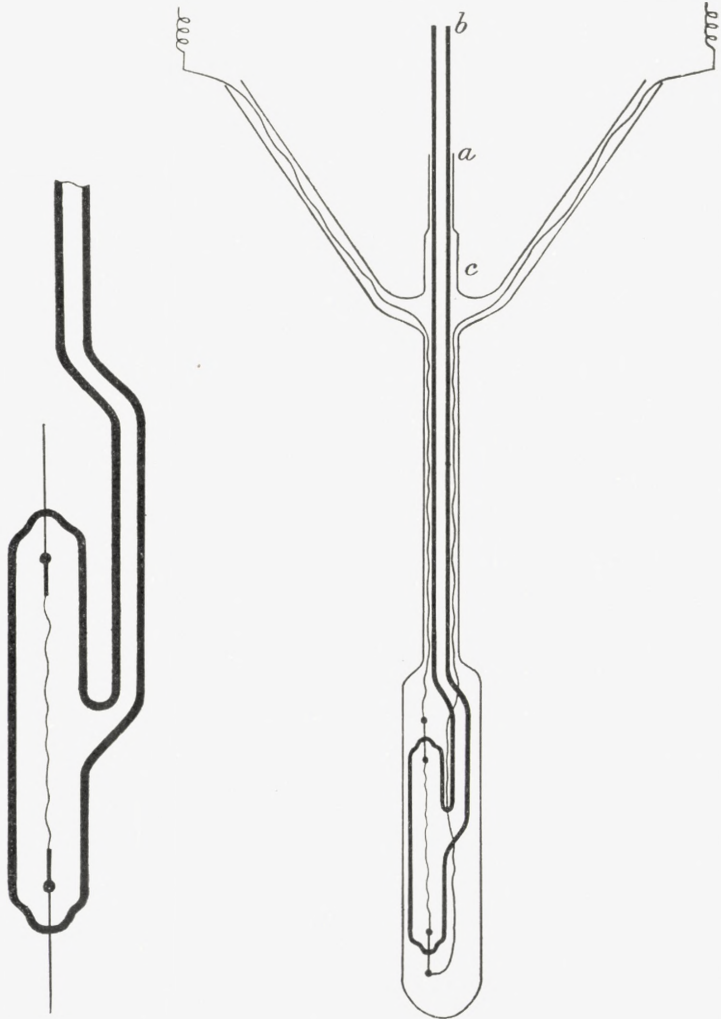

Fig. 1.

Fig. 2.

wires 0.2 mm. thick and about 2 cm. long. The platinum wires and soldered places are immersed in a solution of shellac in alcohol, whereupon the silver is removed from the Wollaston wire in dilute nitric acid. When the shellac has been

removed by immersion in alcohol, and the wire has been cleaned in sulphuric acid and afterwards in distilled water, the wire is put into a small glass tube, into the ends of which the platinum wires are melted. The width of the glass tube is 6 or 7 mm., and its length should not exceed that of the Wollaston wire by more than 1.5 cm. In melting in the platinum wires care should be taken that the Wollaston wire is not tightened. When the tube is held in a horizontal position after the wires have been melted in, the Wollaston wire should hang down in a curve the lowest point of which is about 2 mm. below the soldered places. The glass tube is provided with a side tube about 2 mm. wide, shown full size in fig. 1. To the platinum wires are soldered copper wires (silver solder), whereupon the manometer is put into a glass jacket as shown half size in fig. 2. At *a* (fig. 2) the manometer tube is connected to the glass jacket by a piece of india-rubber tubing, whereupon the glass jacket is filled with pure vaseline oil. At *b* the manometer tube is melted to the apparatus in which it is desired to measure the gas pressure. The glass jacket up to *c* is placed in a cylindrical Dewar vessel filled with scraped ice made from distilled water. Only the temperature of melting ice has proved sufficiently constant when it is desired to get the full benefit of the hot-wire manometer.

The Electrical Arrangement.

The method of measurement is to send an electric current through the Wollaston wire (the manometer wire), and then to increase the current until the resistance of the manometer wire has reached a certain definite value r . In that case the mean temperature T of the manometer wire will also have a definite value, and the heat produced

in the wire will be ri^2 , i being the current. Hence it is only necessary to measure i in order to determine ri^2 , which will vary linearly with the pressure within a considerable range.

To carry out these measurements the manometer wire was placed as the one side of a Wheatstone bridge (fig. 3). Of the three other sides of the bridge two had resistances of 1000 ohms each, and the third had the same resistance as the manometer wire. This third resistance was a plug

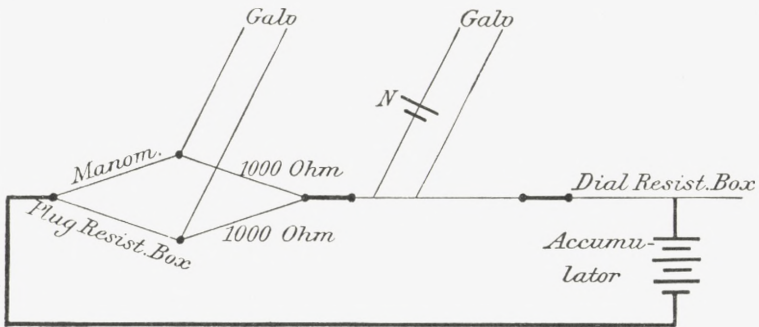

Fig. 3.

resistance that could be varied with tenths of an ohm. The plug resistance and the two standard resistances of 1000 ohms were placed in a bath of vaseline oil as close as possible to the hot-wire manometer. The current was furnished by an accumulator battery of three cells (fig. 3). The cells were rather large and well insulated for heat, in order that their temperature and thus their voltage should not be subject to too rapid changes. The current was varied by a decade dial resistance (fig. 3) allowing of variations with leaps of $\frac{1}{10}$ ohm. It is preferable that the total resistance should be more than 20000 ohms. In some cases a regulation of the current within $\frac{1}{10}$ ohm proved insufficient, and in such cases a standard resistance of 1 ohm

was introduced into the circuit, and this resistance was provided with a variable shunt, preferably a dial resistance.

The current in the main circuit, which is proportional to the current in the manometer wire, was determined in the following way. A potentiometer was introduced into the main circuit (fig. 3). *Raps's* type is particularly well suited for this, since no interchange of resistances occurs upon regulation, while transition resistances in the sliding contacts have very little influence on the total resistance. The fact that the principle of this type of apparatus only allows of the direct determination of four figures of the resistance between the contacts of the galvanometer wire is remedied by employing galvanometer deflection for interpolation. In the galvanometer circuit of the potentiometer is introduced a standard cell *N* (fig. 3). Experience proved that even if a Weston cell was employed, it was necessary to keep the cell at constant temperature. This was achieved by immersing it in a large bath of vaseline oil. The two galvanometers for the Wheatstone bridge and the potentiometer were both of the d'Arsonval type with about 500 ohms resistance in the moving coil. The additional resistance built into the galvanometers was not employed, but each galvanometer was furnished with a variable shunt. Objective mirror reading with the ordinary scale distance of about 1 m. was employed.

One or two difficulties presented by the use of the hot-wire manometer shall now be mentioned. Thus the resistance of the Wollaston wire is sensitive to variations of the magnetic field in which it is placed. This I discovered when it turned out that the bridge galvanometer showed a deflection when I approached a small iron kettle to the manometer. In addition the manometer wire must be guarded

as well as possible against the development of heat from extraneous induction currents in it. Hence it is of importance that the wires of the main circuit are intertisted as far as possible, and are as short as possible. Thus it proved necessary to move the battery from the actual battery room to the room where the measurements were made. The manometer wire was, in addition, shunted with a capacity of 1 microfarad, and the arrangement is now suitable even where work with Röntgen apparatus etc. is going on in adjoining rooms. Finally it may be mentioned that care should be taken that the manometer wire does not receive irregular heat radiation, but this is sufficiently guarded against when, as mentioned above, an ice bath in a silvered Dewar vessel is employed.

The Testing and Use of the Manometer.

When the hot-wire manometer has been immersed in a temperature bath for about 15 minutes, it will have assumed the temperature of the bath with sufficient accuracy. The measurements are then begun by determining the resistance of the wire at 0° , and its temperature coefficient for resistance. The latter is usually 0.0035. A resistance box forming one side of the Wheatstone bridge, these measurements are very easily made with a high gas pressure in the manometer, so that a current sufficient for the measuring may be used without the temperature of the wire rising appreciably. Such an increase of temperature will appear as an increased resistance which may easily be ascertained.

For the manometer wire with which the measurements described in the following were made, the resistance at 0° was found to be 746.9 ohms, while at 49.6° it was 877.6

ohms. The resistance of 900 ohms, corresponding to a mean temperature of the wire of 57.8°C , was then chosen for the measurements. This resistance was kept unaltered throughout the measurements. The length of the Wollaston wire was 3.60 cm., and if we suppose the specific conductivity of the platinum to be $9.1 \times 10^{+4}$, this gives a thickness of wire of 2.6 microns.

In examining the hot-wire manometer the apparatus sketched in fig. 4 was used. In this all the glass joints

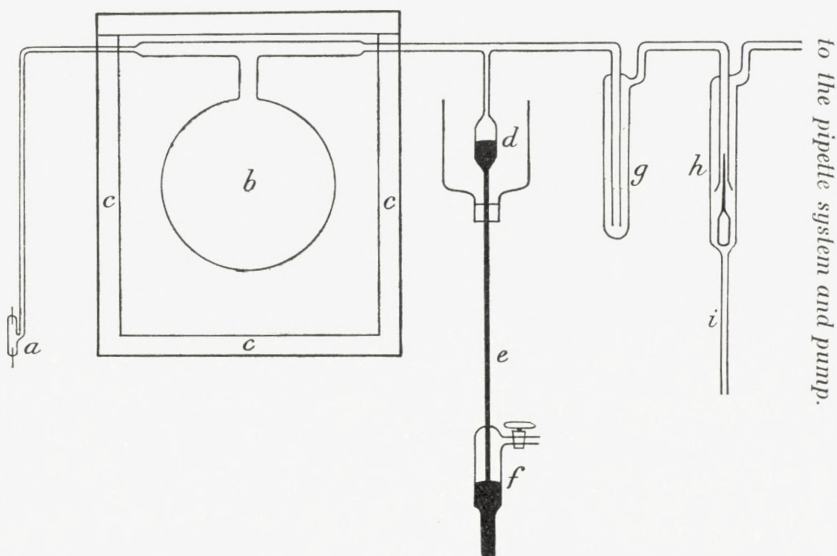

Fig. 4.

were fused. *a* is the hot-wire manometer from which a glass tube leads into a glass vessel *b* of about 1200 cm^3 placed in a water bath (or ice bath) whose walls *c* are well insulating for heat. *d* is a gauge-bulb which may be filled with and emptied of mercury through the tube *e*. Above and below the gauge-bulb the glass tubes are marked. The volume between these marks was found to be 8.8746 cm^3 at 20° . The glass tubes over and just under the gauge-bulb were rather narrow, about 0.5 mm in diameter, in order to offer a very

great resistance to the flow of mercury vapour into the apparatus. The tube *e* was about 2 mm. in diameter and so long that there was a barometric height between the surface of the mercury at the highest mark and the surface of the mercury in the vessel *f*. This vessel is furnished with a stop-cock through which the air may be sucked out with the mouth, the gauge-bulb being thus emptied. If it is desired to fill the latter, the stop-cock need only be opened, but care should be taken that the air flows in through a tube containing chloride of calcium, for any moisture in the vessel *f* will cause water to penetrate into the apparatus between the mercury and the glass. To prevent all adherence of water it will be well to begin by producing a complete vacuum above the mercury in *f*, the apparatus itself being also exhausted of air and dry.

g is an ordinary trap which may be surrounded by liquid air in order to remove the vapours of carbonic acid, water, and mercury from the rest of the apparatus. By the mercury seal *h* the apparatus may be shut off from the remaining parts, the pipette system, pump etc. This seal is made in such a way that, when mercury is made to rise through the tube *i*, the mercury will lift a small glass body with a ground cone, which fits into the lower end of the glass tube coming from the manometer apparatus. If the mercury in *h* is made to rise a little above the ground part, the closure is completely gastight, and only quite minimal quantities of mercury vapour will be able to pass through the ground part. In order to alter the height of the mercury in *h*, that is to say, to open or shut the seal, *i* is provided at the bottom with a mercury receiver exactly like *f*. Such a seal serves as a substitute for a stop-cock, and if there is no reason to shut off

mercury vapour, the ground glass float may of course be dispensed with.

Seals of the above-mentioned description I have employed in a "pipette system" serving to produce a known, small gas pressure in the manometer apparatus. The pipette system is shown schematically in fig. 5. The heavy lines represent glass tubes about 1 cm. wide, the fine lines represent glass capillary tubes of about 1 mm. in diameter; the short

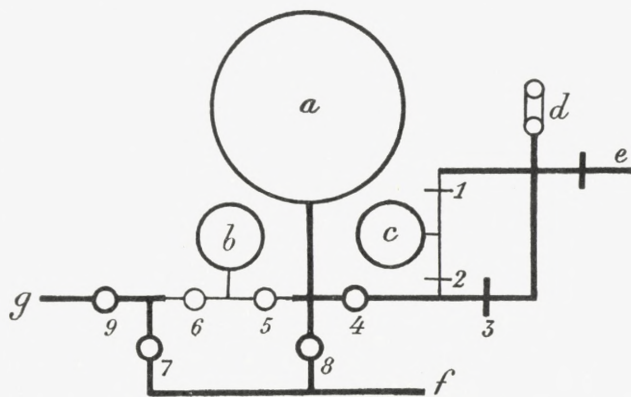

Fig. 5.

heavy transverse lines represent glass stop-cocks of wide bore, the fine ones represent capillary stop-cocks. The small circles represent mercury seals as above-described, the heavy ones represent the wide tubes, the fine ones the narrow tubes. *a*, *b*, and *c* are bulbs placed together in a water bath. *a* has a volume of a little above 4000 cm^3 , *b* and *c* have each a volume of 14 cm^3 . The tube *g* leads to the apparatus with the hot-wire manometer, *g* being the seal with the glass valve mentioned in the description of the last figure. *f* leads to the pump, and *d* represents a mercury manometer. First the whole system is exhausted with the stop-cock *e* closed and all the others open. Next the stop-cocks 2, 3, 7, and 8 are closed, and the gas is introduced through the tube *e*. The pressure in

the mercury manometer is read. If this is P cm. mercury pressure, and cock 1 is closed and cock 2 is afterwards opened, the pressure in the apparatus with the hot-wire manometer will be p (Bar) = 33,310 P . If, instead of letting the gas in c between cocks 1 and 2 escape into the whole of the apparatus, it had only been allowed to go as far as cock 6, and the gas in b between cocks 5 and 6 had then been allowed to spread throughout the apparatus through g , the pressure in the apparatus would be determined by p (Bar) = 0,45457 P . The mercury manometer d being so constructed that it may be read with an accuracy of $1/100$ mm., it will be seen that an apparatus of the dimensions here described allows of the introduction of any pressure from 0.5 bar to 10^6 bar with an accuracy of about 1 per mille.

Measurements with the Hot-Wire Manometer.

The apparatus was exhausted while partly heated by a gas flame. The potentiometer, whose resistance was 11000 ohms, was shunted with a resistance of 2000 ohms. In the Wheatstone bridge the resistance of 900 ohms was chosen. In the dial resistance a very great resistance was chosen, and the bridge galvanometer was shunted so that its sensitivity was very small. If now the current from the battery is put on, the bridge galvanometer will show a deflection, since there is no equilibrium in the Wheatstone bridge. The resistance is now decreased by means of the dials, which will cause an increase in the deflection of the bridge galvanometer, because the current is increased without the manometer wire being appreciably heated. With a continued increase of the current the deflection of the galvanometer will reach a maximum, whereupon it will

again decrease. When it is about zero, the sensitivity of the galvanometer is increased, the final setting of the dial resistance is carried out by employing the greatest sensitivity of the galvanometer. Next the potentiometer is set. When the apparatus was exhausted this setting was 10468 ohms. If the electromotive force of the standard cell is 1.0186 volt, a current of $1,0186/10468$ amp. will thus flow through the potentiometer, and a current $11000/2000$ times as strong will flow through the shunt. Half the sum of these currents flows through the manometer wire, i. e. 0.0003162 amp., producing a heat per sec. of 90×10^{-6} watts. Hydrogen was now introduced into the apparatus, to a pressure of 427.0 bar. The shunt of the potentiometer was altered to 400 ohms. This gave a reading of 9722 ohms on the potentiometer, the current being $0,001493$ amp. and the produced heat 2006×10^{-6} watts. It will be seen that the heat produced is 22.3 times as great as that produced in vacuum.

When the potentiometer was adjusted to 9722 ohms, its galvanometer showed a deflection of 0.8 divisions of the scale; if the adjustment was increased by 1 ohm to 9723 ohms, the deflection was 23.8 mm. in the opposite direction. To the 9722 ohms must thus be added $0.8/(0.8+23.8) = 0.03$. This method of determining the decimals is absolutely preferable to an adjustment of tenths of ohms, even if such a dial is found on the potentiometer.

In order to give some idea of the accuracy of determination a series of measurements were made with the gauge-bulb alternately emptied of and filled with mercury. A filling or emptying with adjustment of the mercury surface to the mark and of both adjustments of the galvanometers took altogether a little less than 8 minutes. The potentiometer readings were as follows:

The gauge-bulb filled with Hg.	9689.66	9689.78	9690.05	9690.19	9690.37
The gauge-bulb emptied of Hg	9722.20	9722.33	9722.52	9722.72	9722.82
Difference	32.54	32.55	32.47	32.53	32.45

The shut off volume of hydrogen, the pressure of which was increased by the filling of the gauge-bulb with mercury, was 1221.22 cm^3 at 20° , while the gauge-bulb held 8.8746 cm^3 . Hence the increase of pressure amounted to $427.0 \times 8.8746 / 1212.345 \text{ bars} = 3.126 \text{ bars}$.

From the above table the following mean values for the potentiometer readings are calculated:

The gauge-bulb filled with mercury	9690.01
— — emptied of mercury	9722.52
Difference	32.51 ± 0.045 .

From this it will appear that the mean error in measuring a difference in pressure of 3.126 bars only amounts to 0.0043 bar, which is $1/100000$ of the pressure at which the measurement was made.

A study of the series of potentiometer readings will show that the figures increase with the time, which means that the pressure decreases. This is presumably due to a slow condensation or adsorption in the tube surrounded by liquid air.

If there were any reason for increasing the sensitivity beyond what has been achieved here, this could undoubtedly be done, it should however be noted that even small variations in temperature in the communication tubes exposed to the air have great influence on the pressure in the manometer. This may be shown by the following example. If a piece of tube is heated by holding a finger on it, the bridge galvanometer will show a deflection, and a quite

similar small local cooling will cause a deflection in the opposite direction.

Between the hot-wire manometer and the about 1200 cm^3 large vessel in the water bath was introduced a tube system as shown in fig. 6. The two downward bent pieces of tube, *a* and *b*, had a bore of about 1 mm., the rest of the tubes

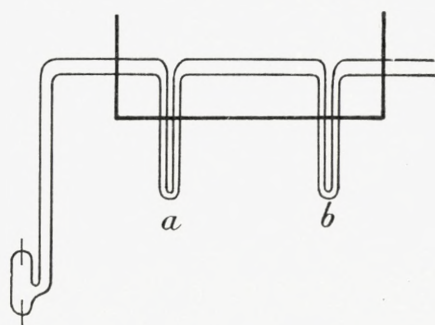

Fig. 6.

were 2 mm. wide. The joints between the unequally wide tubes were placed in a water bath of 20° in order to prevent thermal molecular pressure. The pieces of tube *a* and *b* could be immersed in baths of different temperatures to a depth of 9 cm. At a mean pressure of 427.0 bars the measurements gave the values shown in the table below:

Temperature of <i>a</i>	Temperature of <i>b</i>	Increase of pressure in the hot-wire manometer
-80°	20°	-1.089 bars
$+120^\circ$	20°	$+0.949$ —
20°	-80°	$+1.141$ —
20°	$+120^\circ$	-1.012 —
$+120^\circ$	-80°	$+2.124$ —
-80°	$+120^\circ$	-2.005 —

The volume of air whose temperature was altered by these experiments was 0.16 cm^3 , from which by Gay Lussac's law the change of pressure in the whole system was computed to be less than 0.020 bar. It will be seen that this

change of pressure is quite negligible compared with the variations measured. It will further be seen that when the bend of the tube which is farthest removed from the hot-wire manometer is cooled, this will cause a rise of pressure in the manometer, while heating will cause a fall of pressure. The opposite will be the case with the bend of the tube nearest the manometer, and finally it will appear that the two last experimental results may be fairly accurately produced from the others by addition.

I have assumed that these considerable variations in pressure were due to adsorption phenomena and therefrom arising pumping effects inside the tubes, so that the measurements do not represent conditions in a final state of equilibrium. As I had the idea that water would be particularly effective owing to its great absorption to glass, the experiments in question were made after the bends of the tubes had been kept at a temperature of about 300 centigrade for about 10 hours.

In another series of experiments a bend of the tube was cooled in liquid air. This at once caused a decrease of pressure, which in the course of a quarter of a minute was followed by a considerable increase of pressure. This latter persisted fairly unchanged for some hours, whereupon it slowly decreased. In the course of four days it had only decreased to about half of its maximum value.

The measurements hitherto mentioned were made with glass tubes of the ordinary »Thüring« glass. Some experiments with Jena »Geräte glass« gave somewhat smaller but still considerable temperature effects.